

## Rigidlite® Coupling Fig. 7400



The Fig. 7400 Rigidlite Coupling from Gruvlok is specially designed to provide a rigid, locked-in pipe connection to meet the specific demands of rigid design steel pipe systems. Fast and easy swing-over installation of the rugged lightweight housing produces a secure, rigid pipe joint.

### Material Specifications

#### Bolts

SAE J429, Grade 5, Zinc Electroplated (standard)

#### Heavy Hex Nuts

SAE A563, Grade A, Zinc Electroplated (standard)

#### Hardware Kits

304 Stainless Steel (available in sizes up to ¾")

Kit includes:

- (2) Bolts per ASTM A193, Grade B8 and
- (2) Heavy Hex Nuts per ASTM A194, Grade 8.

#### Hardware Kits (continued)

EcoGuard (available in sizes up to ¾")

Kit includes:

- Bolts per SAE J429, Grade 5, with EcoGuard corrosion-resistant zinc flake coating and
- (2) Heavy Hex Nuts per ASTM A563, Grade A, EcoGuard corrosion-resistant zinc flake coating.

#### Housing

Ductile Iron conforming to ASTM A536, Grade 65-45-12.

### Material Specifications (continued)

#### Coatings

- Rust inhibiting paint
- Color: Orange (standard)
- Hot Dipped Zinc Galvanized (optional)

#### Gaskets

Properties as designated in accordance with ASTM D2000

##### Grade "EP" EPDM (Green and Red color code)

-40°F to 250°F (Service Temperature Range)  
(-40°C to 121°C)

Recommended for water service, diluted acids, alkalis solutions, oil-free air and many other chemical services.

NOT FOR USE IN PETROLEUM APPLICATIONS.

For hot water applications the use of Gruvlok Xtreme Temperature lubricant is recommended. NSF-61 Certified.

##### Grade "T" Nitrile (Orange color code)

NOT FOR USE IN DRINKING WATER

-20°F to 180°F (Service Temperature Range)  
(-29°C to 82°C)

Recommended for petroleum applications. Air with oil vapors and vegetable and mineral oils.

NOT FOR USE IN HOT WATER OR HOT AIR

##### Grade "L" Silicone (Red color code)

NOT FOR USE IN DRINKING WATER

Size Range: 1" - 8" (C style only)

-40°F to 350°F (Service Temperature Range)  
(-40°C to 177°C)

Recommended for dry, hot air and some high temperature chemical services.

#### Gasket Type

- Standard C Style (1" - 8")
- Flush Gap (1" - 8")

#### Lubrication

- Standard Gruvlok
- Gruvlok Xtreme (Do Not use for Grade "L")



PROJECT INFORMATION	APPROVAL STAMP
Project:	Approved
Address:	Approved as noted
Contractor:	Not approved
Engineer:	Remarks:
Submittal Date:	
Notes 1:	
Notes 2:	

## Rigidlite® Coupling Fig. 7400

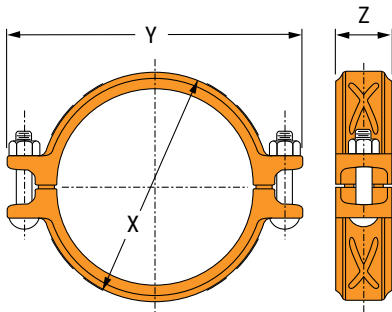

Nominal Size	O.D.	Max. Working Pressure on Sched. 40	Max. Working Pressure on Sched. 10	Max. End Load	Nominal Range of Pipe End Separation	Dimensions			Qty.	Size	Approx. Wt. Ea.
						x	Y	Z			
In./DN(mm)	In./mm	PSI/bar	PSI/bar	Lbs./kN	In./mm	In./mm	In./mm	In./mm	In./mm	Lbs./kg	
1 25	1.315 33.4	300 20.7	300 20.7	407 1.81	0-0.13 0-3.18	2 1/4 57	4 1/2 114	1 3/4 44	2	3/8 x 2 1/4 M10 x 57	1.2 0.5
1 1/4 32	1.660 42.2	300 20.7	300 20.7	649 2.89	0-0.13 0-3.18	2 5/8 67	4 3/4 121	1 3/4 44	2	3/8 x 2 1/4 M10 x 57	1.3 0.6
1 1/2 40	1.900 48.3	300 20.7	300 20.7	851 3.78	0-0.13 0-3.18	2 7/8 73	4 7/8 124	1 3/4 44	2	3/8 x 2 1/4 M10 x 57	1.4 0.6
2 50	2.375 60.3	300 20.7	300 20.7	1,329 5.91	0-0.13 0-3.18	3 1/4 83	5 1/2 140	1 3/4 44	2	3/8 x 2 1/4 M10 x 57	1.6 0.7
2 1/2 65	2.875 73.0	300 20.7	300 20.7	1,948 8.66	0-0.13 0-3.18	2 7/8 98	6 152	1 3/4 44	2	3/8 x 2 1/4 M10 x 57	1.9 0.9
3 O.D. 76.1	2.996 76.1	300 20.7	- -	2,115 9.41	0-0.13 0-3.18	4 102	5 7/8 149	1 3/4 44	2	3/8 x 2 1/4 M10 x 57	1.9 0.9
3 80	3.500 88.9	300 20.7	300 20.7	2,886 12.84	0-0.13 0-3.18	4 1/2 114	6 1/4 159	1 3/4 44	2	3/8 x 3 M10 x 70	2.4 1.1
4 100	4.500 114.3	300 20.7	300 20.7	4,771 21.22	0-0.25 0-6.35	5 3/4 146	7 7/16 189	1 7/8 48	2	3/8 x 3 M10 x 70	3.5 1.6
5 1/2 O.D. 139.7	5.500 139.7	300 20.7	- -	7,127 31.70	0-0.25 0-6.35	6 3/4 171	9 1/4 235	2 51	2	1/2 x 3 M12 x 76	4.5 2.0
5 125	5.563 141.3	300 20.7	300 20.7	7,292 32.44	0-0.25 0-6.35	6 15/16 173	8 15/16 227	1 7/8 48	2	1/2 x 3 M12 x 70	4.5 2.0
6 1/2 O.D. 165.1	6.500 165.1	300 20.7	- -	9,955 44.28	0-0.25 0-6.35	7 3/4 200	10 3/8 264	2 51	2	1/2 x 3 M12 x 76	5.5 2.5
6 150	6.625 168.3	300 20.7	300 20.7	10,341 46.00	0-0.25 0-6.35	7 7/8 200	10 1/16 256	1 15/16 49	2	1/2 x 3 M12 x 70	5.4 2.4
8 200	8.625 219.1	300 20.7	175 12.1	17,528 77.97	0-0.25 0-6.35	10 1/8 257	12 7/16 316	2 3/8 60	2	1/2 x 3 M12 x 70	9.5 4.3

### Notes:

Maximum end load is defined as the max allowable force from the combination of internal pressure thrust at the pipe joint and external loads based on the use of standard ASME B36.10 pipe that is grooved in accordance with ASC's groove specification.

Pressure ratings and end loads may differ for other pipe materials and/or wall thicknesses.

See Gruvlok Coupling Working Pressure Ratings document published in the resources section of the website for pressure ratings on alternate pipe materials.



asc-es.com

Building connections that last™

## Fig. 7400 Rigidlite® Coupling



Read and understand all instructions before use.

### WARNING

Ensure system is drained and depressurized before installation or service.

Use appropriate personal protective equipment.



Failure to follow these instructions could result in serious personal injury and/or property damage.

Check pipe ends for proper grooved dimensions and to ensure that the pipe is free of indentations, projections, or other imperfections that would prevent proper sealing of the gasket.

### 1 Check & Lubricate Gasket

Check gasket to be sure it is compatible for the intended service. Apply a thin coating of Gruvlok lubricant to the exterior surface and sealing lips of the gasket. Some applications require lubrication of the entire gasket surface. Be careful that foreign particles do not adhere to lubricated surfaces.

**Notice:** Gruvlok Xtreme Lubricant is recommended when used in dry pipe systems or freezer applications. separation. Pipe joint separation may result in significant property damage and serious injury.



### 2 Gasket Installation

Slip the gasket over the pipe end making sure the gasket lip does not overhang the pipe end.

On couplings 10" and larger it may be easier to turn the gasket inside out then lubricate and slide the gasket over the pipe end as shown.

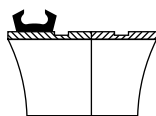

### 3 Alignment

After aligning the two pipe ends, pull the gasket into position centering it between the grooves on each pipe. Gasket should not extend into the groove on either pipe.

On couplings 10" and larger, flip or roll the gasket into centered position.

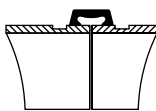

### 4 Housings

Remove one nut and bolt and loosen the other nut. Place one housing over the gasket, making sure the housing keys fit into the pipe grooves. Swing the other housing over the gasket and into the grooves on both pipes, making sure the tongue and recess of each housing is properly mated. Reinsert the bolt and run-up both nuts finger tight.



### 5 Tighten Nuts

Securely tighten nuts alternately and equally, keeping the gaps at the bolt pads evenly spaced.



**Notice:** Uneven tightening may cause the gasket to pinch. Gasket should not be visible between segments after bolts are tightened.

**WARNING:** Proper tightening of coupling bolts is required to obtain specified performance. Over tightening the bolts may result in joint damage. Pipe joint separation may result in significant property damage and serious injury.

### 6 Assembly is Complete

Visually inspect the pipe joint to assure the coupling keys are fully engaged in the pipe grooves. The bolt pads are to have equal gaps on each side of the coupling.

**Notice:** Visually inspect both sides of the coupling to ensure gaps between bolt pads are evenly spaced and are parallel. Any deviations must be corrected before placing coupling into service.

**Notice:** Sizes 16" and larger are cast in multiple segments. To install the larger sizes align the tongue and pocket of the couplings appropriately and tighten the nuts alternately to the specified bolt torque. When properly assembled there will be a small equal gap between the adjacent bolt pads.

#### Maximum Bolt Torque

Bolt Size (In.)	Wrench Size (In.)	Ft-Lbs
3/8	11/16	50
1/2	7/8	120



asc-es.com

Building connections that last™